

SPECIFICATIONS  
FOR  
DESIGN AND MARKING  
CONTROL SURVEY TRAVERSES  
SURVEY INTEGRATION

New South Wales

Produced by Department of lands

2nd Edition 1975

75-291

**Caution:**

*This document has been prepared by scanning the original 1975 Specifications for Design and Marking Control Surveys Traverses and using optical character recognition software to create text. There may be scanning and character identification errors within this document. Care has been taken to correct errors in reproduction, however, if there are any doubts to the correct description or interpretation, reference to the original 1975 text should be made to verify the authenticity of the text.*

SPECIFICATIONS  
for the  
DESIGN AND MARKING  
of  
CONTROL SURVEY TRAVERSES  
SURVEY INTEGRATION - NEW SOUTH WALES

## 1. INTRODUCTION

No survey can have lasting significance unless the marks placed are durable, stable, recognisable and situated to accord with anticipated future use. State Control Survey Marks should be located for permanence in keeping with the prime requirement of intervisibility. Easy access to the marks is essential to provide positive position, direction and height.

There is no doubt that the value and life of the State Control Survey will depend very largely on the stability, density and durability of the marking. Accordingly, site selection can be considered as the most important part of the whole operation. The thought, investigation, care and liaison necessary to properly effect this work will pay handsome dividends in the future.

## 2. TRAVERSE DESIGN AND STATION SITE SELECTION

### 2.1. Design.

The design of Control Survey traverses will be mostly dictated by topographical features and structures such as hills, vegetation, roads and buildings. In urban and fringe urban areas, traverses will usually be confined to the street pattern. In these circumstances, the design should aim at placing not more than 5 intermediate stations between traverse junction points. In non-urban areas, the traverse stations will most likely be in the road reservation, but the sight lines can usually cross the open country alongside the road. The number of stations between junction points and the length of the traverse legs will vary according to the road pattern and topographical detail.

A point in the survey which is to be fixed by intersection alone, e.g. a church spire, ideally should be fixed by four rays of equal length intersecting it at right angles. In practice, this ideal is rarely obtainable, but it should be approached as closely as possible.

In all cases when designing traverses, the aim must be for sound, well constructed geometric figures compatible with the extension of the network into the adjoining areas. The design of cross ties firmly braced into the geodetic framework or into control of higher order is essential.

### 2.2. Horizontal Control.

There are several factors which must be considered when choosing the site for a horizontal control traverse station:-

- The instrument standpoints must be the permanent station marks.
- Intervisibility between stations is to be maintained. Consideration must also be given to the extension of the traverse into adjoining areas.

- The position chosen must ensure that the mark will not be disturbed or the sight lines obscured. Subject to the intervisibility of the main station marks, permanence of all emplaced marks is essential to the concept of integrated surveys. Due consideration must therefore be given to such things as services and utilities in footpaths and carriageways, future road widening proposals, drainage areas and places where erosion or surface change may occur. The location of services in the footpath area as recommended by the Streets Opening Conference is illustrated in Appendix A. In addition, the requirements of the individual Council should be ascertained.
- As near as possible, adjoining traverse legs are to be of equal length. However, this consideration is secondary to the points outlined above.
- Lines of sight should clear all obstructions by at least one metre.
- All Government and Local Government authorities responsible for local services, roadways and utilities must be consulted regarding future plans for development and any relocation of services. This applies particularly to the local Council Engineer and, as Council will be responsible for the care and maintenance of the marks, agreement as to location, density of stations and witness marks and general specifications for stability in local conditions, should be obtained before the design is submitted.
- Under part VIA of the Posts and Telegraphs Act 1901-1966 it is necessary to contact the local Divisional Engineer of the Postmaster General's Department with regard to the location of existing and future PMG installations. The Divisional Engineer's concurrence in the location and method of construction of the proposed works is to be obtained, and the opportunity should be taken to impress upon PMG officers the necessity for the preservation of state control survey marks and other survey marks.
- At each station site where traverse legs are longer than 500 metres or where the mark must be placed in a position of doubtful permanency, a site is to be chosen for one witness mark. The site should be selected for permanence, be within 50 metres of the main mark, and be intervisible with at least one adjoining main traverse station.
- Final site selection is necessarily a compromise in most cases, but due consideration must be given to all design aspects before making that selection. For this reason, traverse design, planning, reconnaissance and selection of station sites is to be undertaken by experienced survey personnel.

### 2.3. Vertical Control.

Under the general concepts of Survey Integration, marks are not placed solely for levelling purposes. However, if this becomes necessary under particular circumstances, the marks should be placed on the premise that they will form part of a complete State Control Survey network in the future.

### 2.4. Length of Sight.

The optimum length of sight for horizontal traverses is as follows:-

- Urban. The desirable length in urban and fringe urban areas is 500 metres.
- Non Urban. Traverse legs in non-urban areas should be about 1000 metres in length, and should not exceed 1400 metres.

The desirable minimum length of sight is 200 metres.

## **2.5. Plans and Reports.**

A diagram sufficiently detailed to allow the marking party to accurately place the mark should be prepared for each station site selected. This should take the form of a field book sketch plan, oriented to North, showing the location of the Station and the traverse lines. The magnetic bearings are to be shown together with an indication of the type of marking required at the site.

A plan of the overall traverse design is to be prepared indicating all designed lines of sight, including any proposed connections to intersected marks or to existing State Control Survey Marks, trigonometrical stations and other marks. The symbol code, detailed in Appendix B, is to be used.

A report on the traverse design is to be prepared, detailing any irregularities, giving reasons for any departures from the specifications, and indicating any places where marking or traversing difficulties are expected. The report is to contain details of any sites where special marks are required, such as deep marks for unstable ground, and details of existing marks which are to be used in the traverse. The report should also detail the local authorities interviewed and any special requirements of these organisations.

## **3. TYPES OF MARKS**

Most State Control Survey Traverse stations will be marked by Permanent Marks or State Survey Marks. Secure marks established by other authorities can be used and may be designated either as Permanent Marks or Miscellaneous Survey Marks. When an existing trigonometrical station is to be replaced by a concrete pillar, the practice is to construct the pillar nearby and use the old mark as a witness mark. Brass triangles and copper spikes will be used as witness marks to traverse stations in the absence of a suitable existing mark. (See specification for the Establishment and Maintenance of Trigonometrical Stations).

### **3.1. Permanent Marks.**

A permanent mark will consist of a stainless steel rod, or a brass rod with a stainless steel insert, set in concrete or cemented into rock. When the mark is established in a concrete block, it is set below ground level and covered with a cast iron cover box, set flush with the surface. The number plate relating to the mark is affixed to the inside of the cover box lid or to the rock. The specifications for this type of mark are detailed in Appendix "C".

In unstable ground, a special Permanent Mark is used to ensure stability. This consists of a long (up to 4.0m) manganese bronze rod in an auger hole. The lower end is set in concrete, the hole back-filled with a sand/gravel mix and the top covered with a cast iron cover box and lid supported on a terra cotta pipe. The specifications are detailed in Appendix "D".

### **3.2. State Survey Marks.**

A standard brass or bronze plaque, set into a concrete block or cemented into existing concrete, rock or masonry, is known as a State Survey Mark. The identification number is pre-stamped on the face of the plaque. Specifications are detailed in Appendix "E".

### 3.3. Trigonometrical Stations.

The stone cairn type and, in some cases, the metal tripod or quadripod type of trigonometrical station are being replaced by a concrete pillar or by a vertical steel pipe stand designed for use on the top of elevated buildings or reservoirs. In most cases the original station mark will serve as a witness mark to the new station but, where this is not suitable, a new witness mark is to be placed.

### 3.4. Pillars.

A trigonometrical pillar is a tapered reinforced concrete stand set on a reinforced concrete base. On the top of the stand is an engraved stainless steel plate containing a threaded spigot for attachment of a theodolite, signal or target. A mast and vanes is usually attached to the stand. Specifications are detailed in Appendix "F".

### 3.5. Beacons on Elevated Structures.

The beacon consists of a galvanised iron instrument stand, observing plate with threaded spigot and detachable mast and vanes. Specifications are detailed in Appendix "G". When placed on a reservoir a platform as illustrated in Appendix "L" shall be constructed.

### 3.6. Witness Marks.

The purpose of a witness mark is to verify the stability of the traverse station and to provide an alternative co-ordinated point. The following types of marks can be adopted:-

- Existing survey marks comprising permanent marks, reference marks (G.I. pipe, drill hole and wing, concrete block, or an alignment mark). These marks are to be used whenever they fulfill the requirements for witness marks detailed above.
- A flat brass triangle, stamped "SURVEY", recessed into existing concrete, rock or masonry and firmly attached with epoxy resin and a copper or brass nail. Specifications are detailed in Appendix "H".
- A copper spike in a concrete block set below the natural surface. This mark is designed for use in non-urban areas. Specifications are detailed in Appendix "I".

## 4. NUMBERING OF MARKS

### 4.1. Mark Numbers.

Mark numbers will be allotted by Survey Co-ordination Branch and numbered plates with permanent marks, also pre-numbered state survey marks will be distributed from the local office by the District Surveyor or in the Sydney-Newcastle-Wollongong area by the Chief Surveyor, Integration Surveys.

Station numbers are allotted from the series pertaining to five types of marks detailed below:-

- Permanent Marks (abbreviation PM) are numbered serially from 1 with the prefix PM. Where a suitable unnumbered mark established by another authority is adopted an identification number will be assigned from the PM series.

- State Survey Marks (abbreviation SSM) are numbered serially from 1 with the prefix SSM.
- Trigonometrical Stations (abbreviation TS) will be numbered serially from 1. Existing stations that are named will retain that name and in addition will be allocated a number. New Trigonometrical Stations will not as a general rule be named, however, a station may be named if there are special circumstances such as the station name indicating the locality of the mark. Names must not be duplicated and will require approval of the Geographical Names Board before adoption.
- Miscellaneous Survey Marks (abbreviation MSM) are numbered serially from 1 with the prefix MSM. Established Numbered Marks in any prior series will be renumbered in the MSM series and both numbers will be recorded on the sketch plan and the Control Survey Plan in addition to a cross reference maintained in the Survey Co-ordination Branch.
- Geodetic Stations (abbreviation GS) are the responsibility of the Central Mapping Authority and are not subject to these specifications. It is intended that in addition to being named Geodetic Stations will be numbered serially from 1.

#### 4.2. Code System for Marks.

A unique identifying reference code system employing up to thirty-one characters has been established.

The code is comprised of the four separate descriptive components detailed below:-

- A physical component utilising up to three alphabetic characters (PM, SSM TS, GS and MSM).
- An identification number component utilising up to 5 digits recording the number of the particular mark.
- A witness mark-component, consisting of to two alphabetic characters and a sequence digit, added after the main station identifying code number. (For example SSM 12345BT1).
- A text component, which can contain up to twenty characters, for recording any station name or existing mark number. The text component is contained in brackets. The twenty characters include punctuation marks and spaces but not the brackets.

#### 4.3. Witness Mark Abbreviations.

A schedule of abbreviations to be used for witness marks is as follows:-

Alignment Pin	- IP
Alignment Post	- AP
Bench Mark	- BM
Brass Triangle	- BT
Concrete Block	- CB
Copper spike in concrete	- CS
Drill Hole	- DH
G.I. Pipe	- GP
Iron Spike or Bolt	- IS
Other Mark	- OM

"Other Mark" is to be used for the many miscellaneous marks existing at the present time and the classification "Bench Mark - BM" is to be used to describe all existing bench marks of a miscellaneous type, placed by Government Departments, Local Government or Private Surveyors.

These abbreviations are not to be used on Locality Sketch Plans or on field book diagrams. The full description is to be given in this section of the field notes to allow ready identification of the mark in the future.

## 5. PLACING STATION MARKS IN EXISTING STRUCTURES

A standard Permanent Mark should be placed in stable soil unless existing structures or solid rock can be utilised to place a State Survey Mark. Other marks, such as special permanent marks, trigonometrical pillars and beacons should only be placed where conditions are appropriate.

Permanent Marks or State Survey Marks which are placed in existing structures or in solid rock are to be let into the full depth of the mark. The stem of the mark is not to be cut. The "legs" on the bottom of the State Survey Mark plaque are to be bent apart as indicated in diagram. The hole should be drilled to the required depth and any flaking material removed. The top of the hole to house the SSM should be enlarged as shown in the diagram, Appendix "E".

The mark is to be cemented into the hole, using either a grout, consisting of 2 parts of sharp clean sand and 1 part of cement mixed with water to a semi-liquid state, or an epoxy resin mixed according to the manufacturer's directions.

## 6. SITE CLEANLINESS

Concrete should be mixed on a flat clean sheet of wood, iron or similar material, or in a wheelbarrow. Epoxy resin should be mixed on a similar sheet or on cardboard, or in a clean tin or jar. Concrete should not be mixed on paths, kerbs, carriageways or the like unless the residue is carefully washed off and the site left unmarked.

On completion of marking, the site is to be tidied and cleared of all debris. All spoil is to be either removed or scattered as appropriate. Turfs should be carefully replaced and the site restored.

## 7. LOCALITY SKETCH PLAN

A Locality Sketch Plan on the appropriate form is to be prepared for each State Control Survey Mark as indicated in Appendix "J" or "K". The diagram is to be drawn oriented to the north and is to show the Magnetic Bearing of the traverse lines. The magnetic bearing and any distance to any witness mark or nearby survey marks should be recorded. Connection should also be made to sufficient surrounding features (such as buildings, fences, gates, kerbs, hydrant boxes, stop valve covers, manholes, PMG boxes, power and telephone poles, road signs, road and track centre or side lines) to allow the mark to be readily found. The certificate is to be completed in all detail.

Care and neatness are essential in the preparation of Sketch Plans, as they will become the permanent record of the placement of the mark in the files of Survey Co-ordination Branch. The sketch should be suitable for reproduction with xerox or similar equipment.

Abbreviations as shown in the schedule in paragraph 4.3 are not to be used on the Locality Sketch Plan. Other abbreviations should be avoided for structure to which ties are made. Under no circumstances should a mark be shown as a "witness mark" or abbreviated to "WM".

APPENDIX "A"

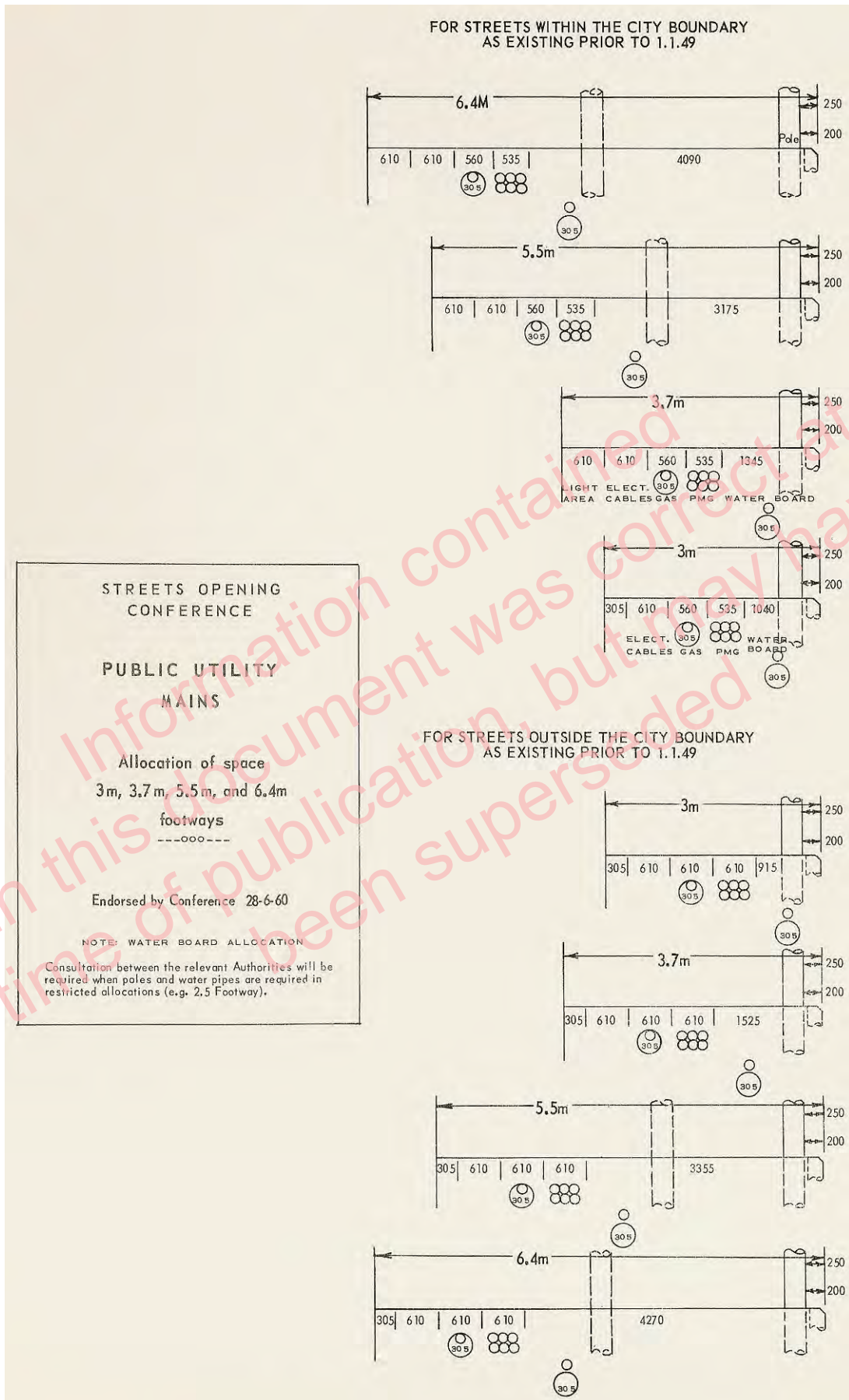





SURVEY INTEGRATION

SYMBOL CODE

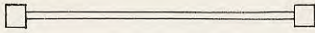
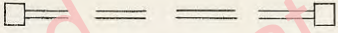
TO BE ADOPTED FOR USE IN ALL DIAGRAMS ILLUSTRATING FIELD WORK.

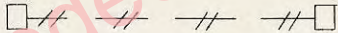
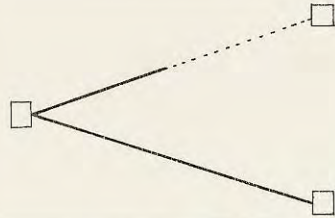
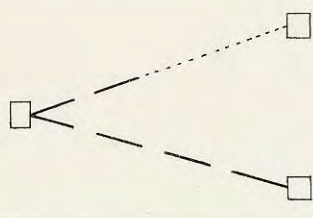
	Previously Completed Work	Work to be done
Second Order <b>LEVELLING</b> Third Order		
Primary <b>DISTANCES</b> Secondary <small>Where precise Chainage was used note with letter C</small>		
<b>DIRECTIONS</b>		

Information contained in this document was correct at time of publication, but may have been superseded

STATE CONTROL SURVEY MARKS

PERMANENT MARKS

MAP SYMBOL 

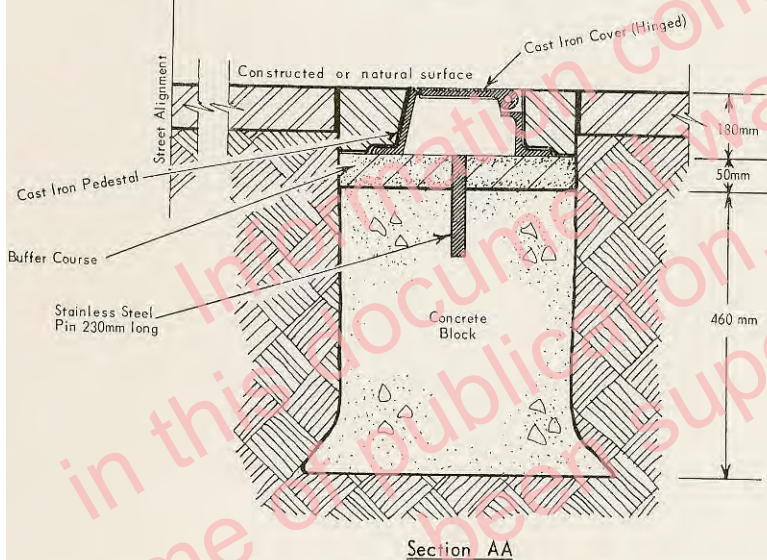
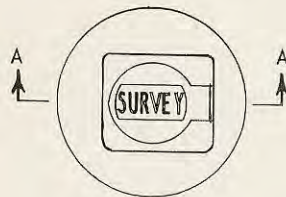
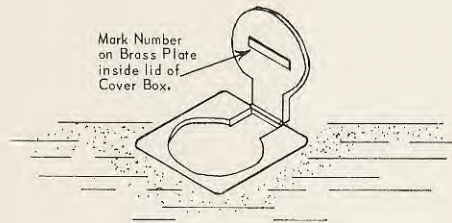

Standard Type Permanent Mark

Minimum size of concrete 460mm deep by 380mm square enlarged at the bottom. Where solid rock is met with, depth may be varied.

In localities where ground is unstable the dimensions must be increased.

The stainless steel pin is to protrude 50mm above the surface of the concrete block.

The buffer course is to be a 50mm layer of crushed brick, gravel or coarse sand.

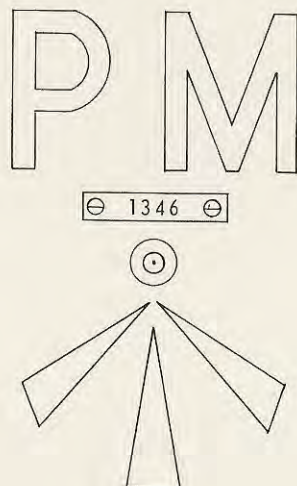

Permanent Mark in Rock

The pin and plate is to be fixed by grouting with a 3:1 sand-cement mixture, or with epoxy resin mixed to the manufacturers specifications.

The letters P.M. and the Broad Arrow should be 100mm long and at least 10mm deep cut into the rock.

The top of the pin should project at least 5mm above the surface and the number plate should be fitted into a recess so that the top of the plate is at least 2mm below the surface of the rock.

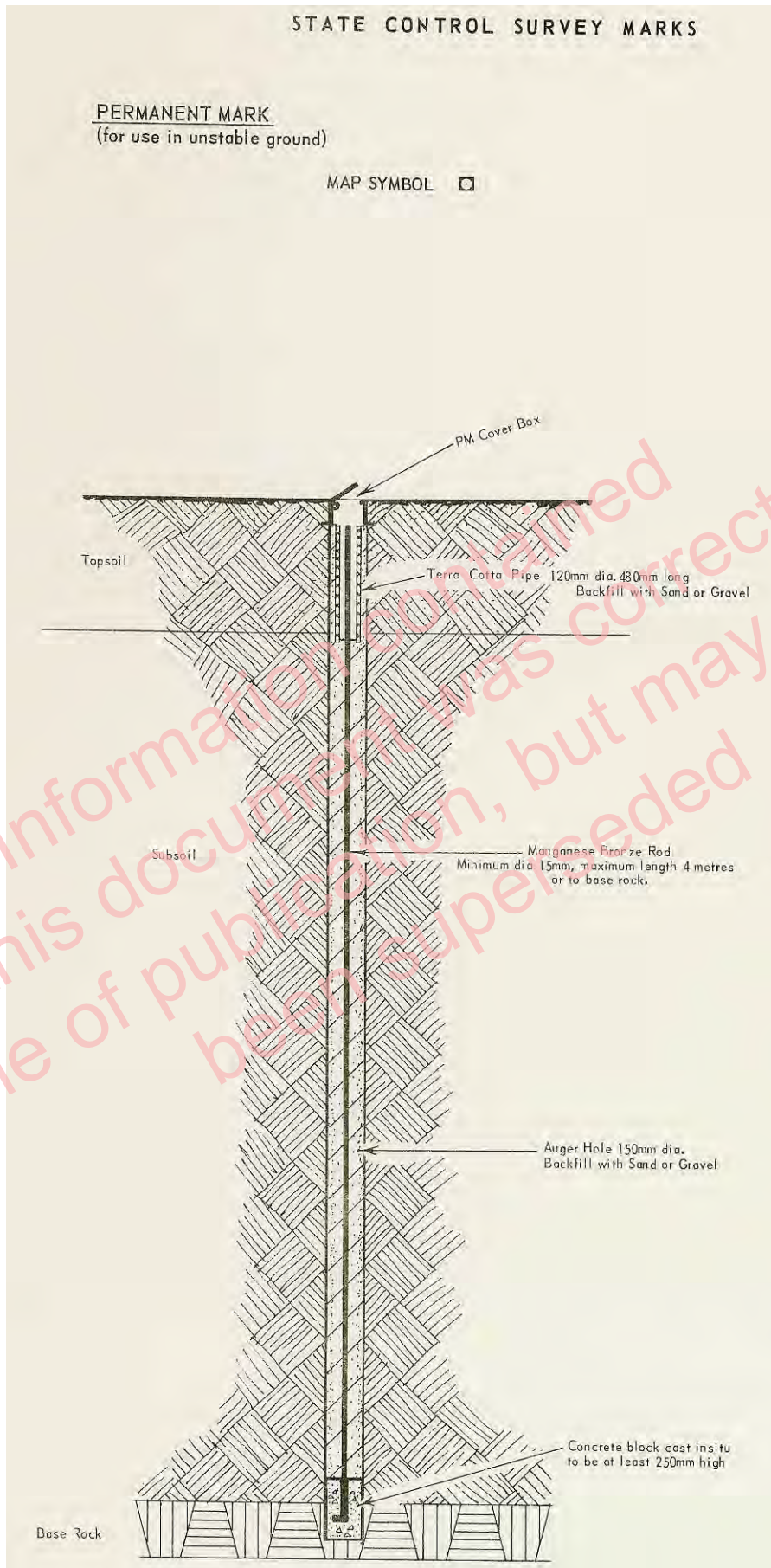

APPENDIX "E"

STATE CONTROL SURVEY MARKS

STATE SURVEY MARK (SSM)

MAP SYMBOL 



NOTE:

Where an existing Structure or Solid Rock is unavailable the mark is to be placed in the top of a concrete block & cast in situ, having a volume of at least .03 cubic metres, and shaped as shown below.

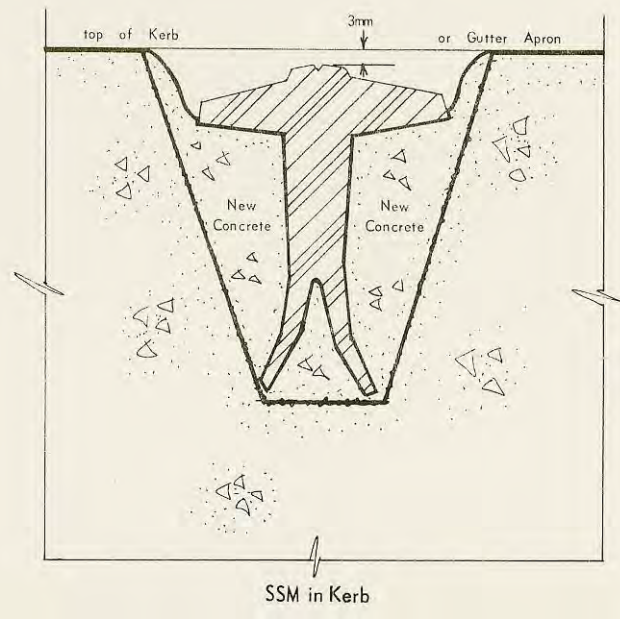
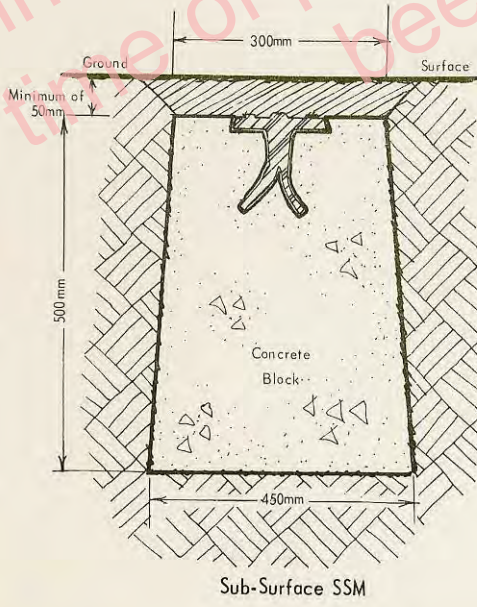
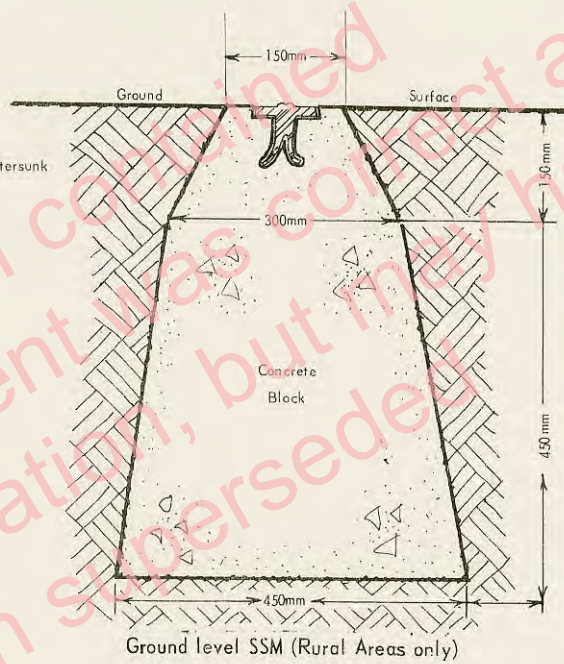
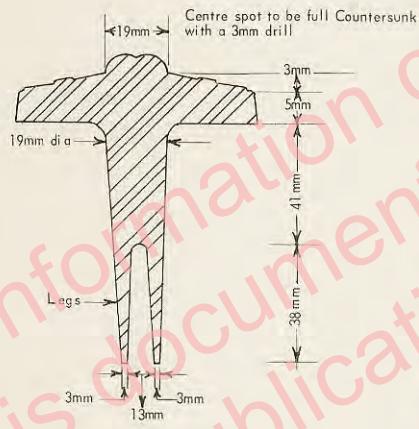

STATE CONTROL SURVEY MARKS

TRIGONOMETRICAL PILLAR

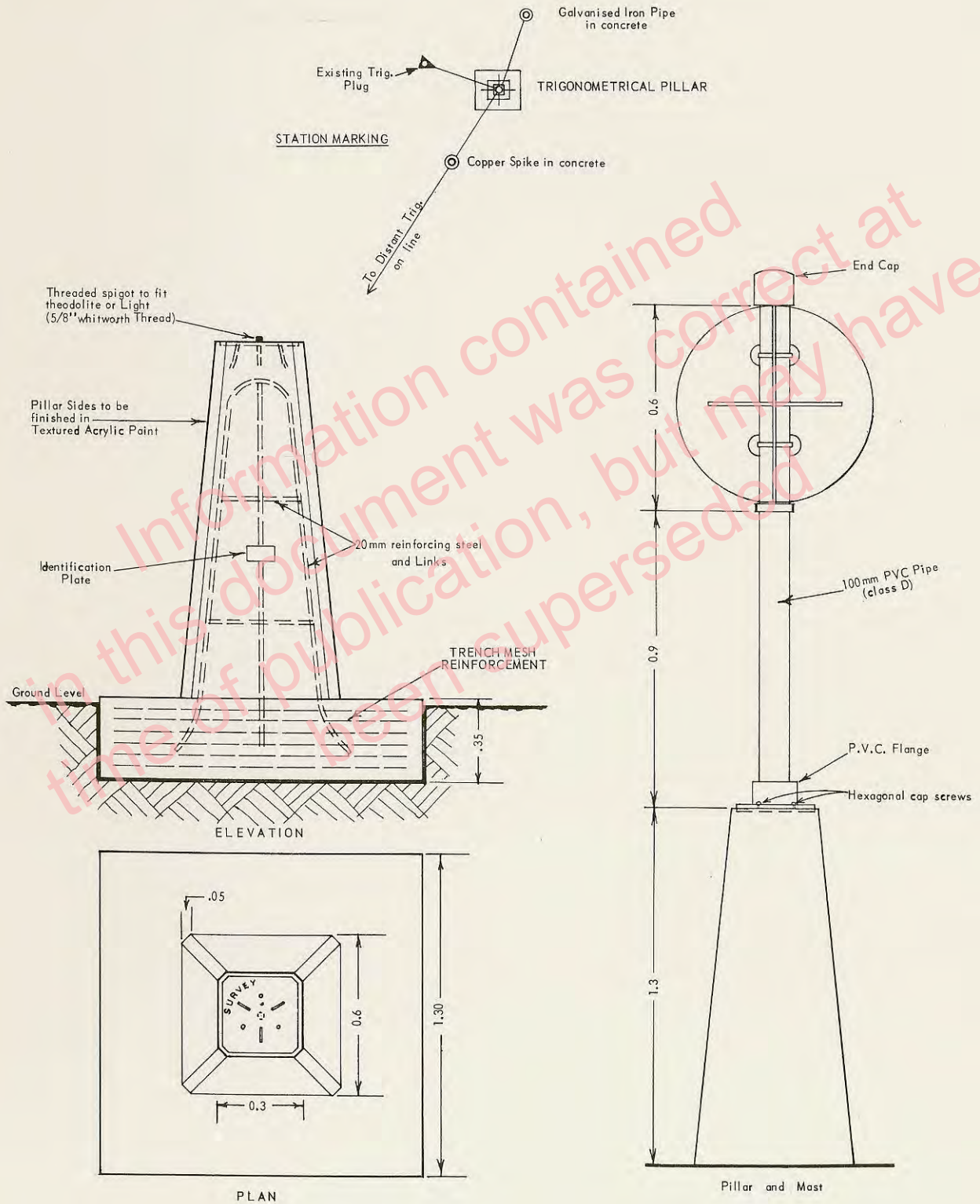

APPENDIX "G", "H", "I"

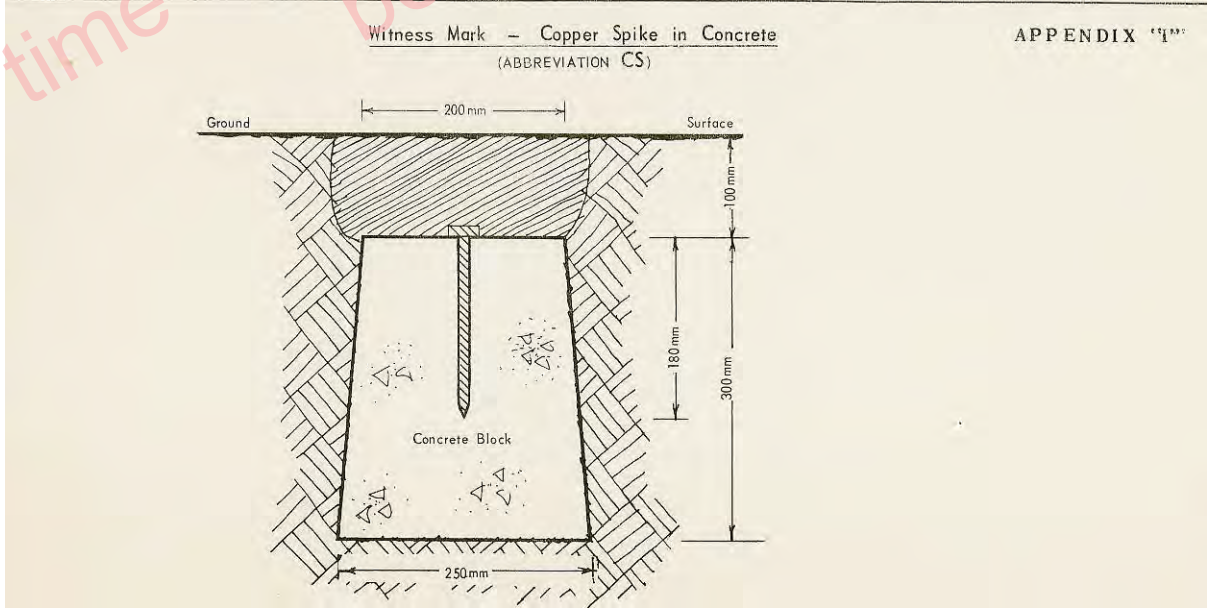
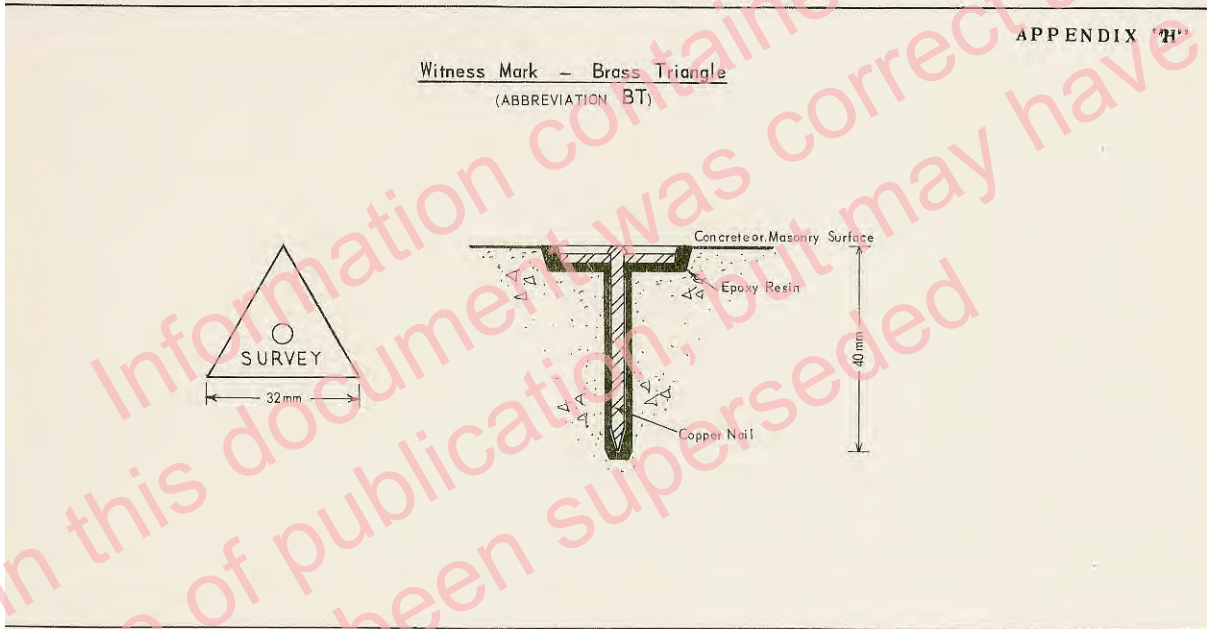
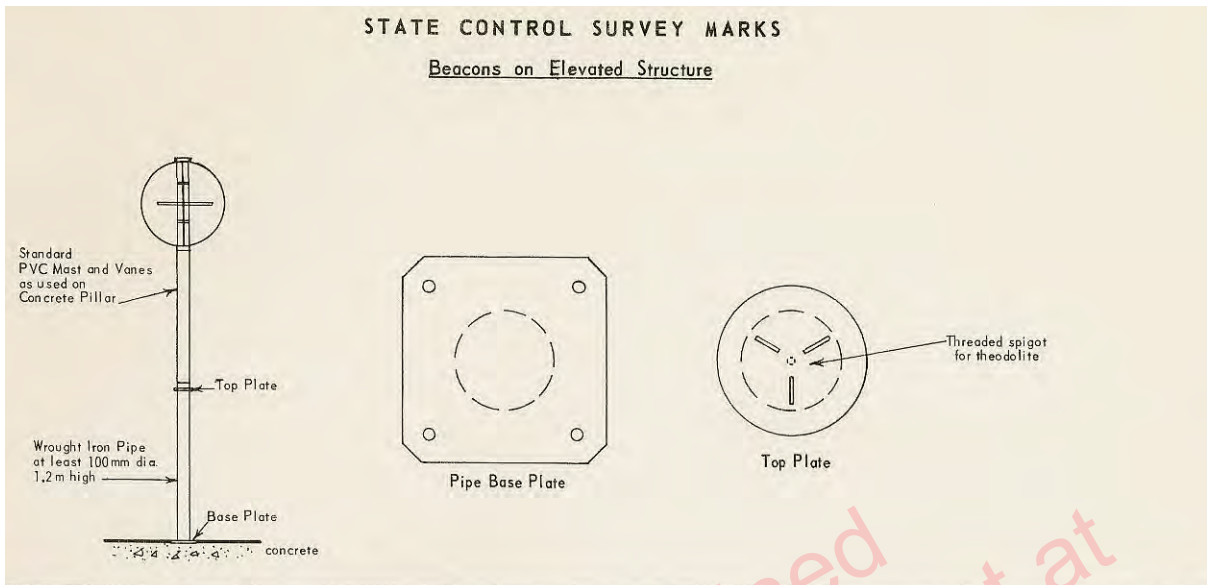



**PM** 16065  
**SSM**  
**M<sub>S</sub>M**

**LOCALITY SKETCH PLAN**

Parish **Boyd**.....County **Terranora**.....City **Tweed**.....  
 Municipality or Shire **Tweed**.....Control Survey Plan.....

Measurements are in metres Zone...56/.2...

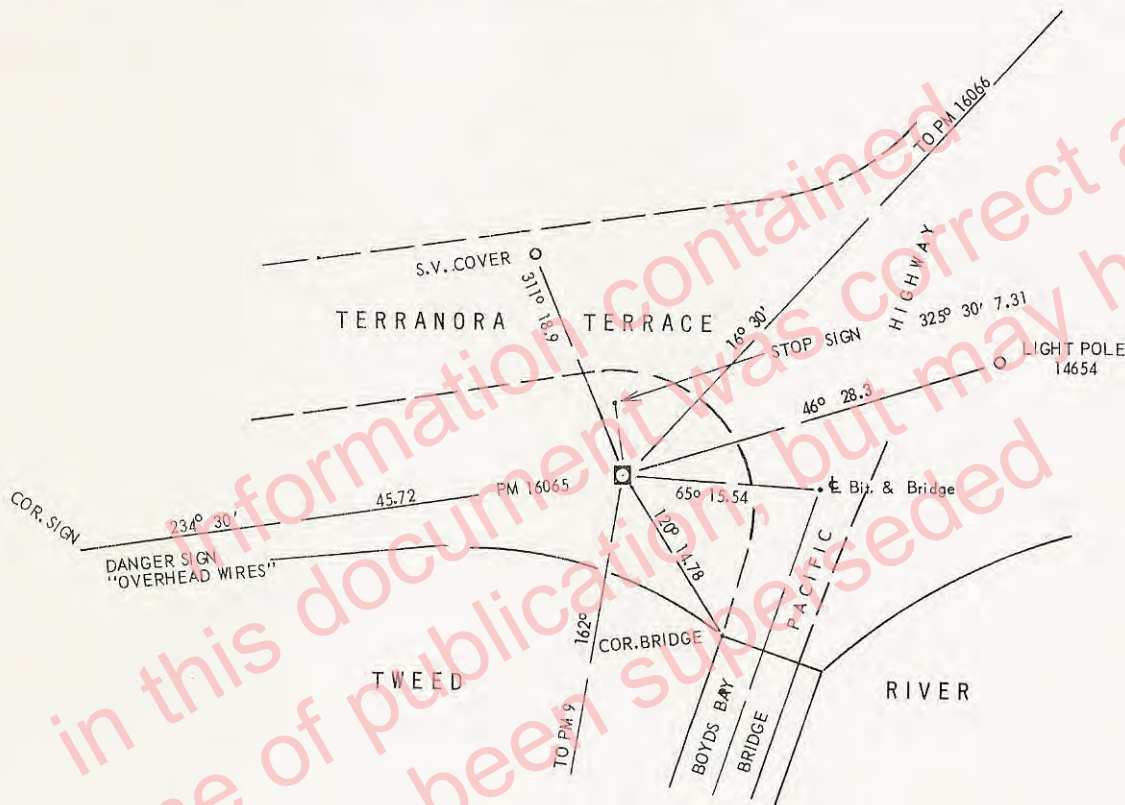

Organisation placing Marks

Tweed Municipal Council  
 Aerial photo No. .... Run .....  
 Plan registered / /19  
 Mark last inspected / /19

**PM** 16065  
**SSM**  
**M<sub>S</sub>M**

I certify that the Mark or Marks have been placed and numbered as detailed hereon.

*John Smith* 5th June 1974  
 Designation  
 Registered Surveyor



PM .....  
 SSM 6702 .....  
 M<sub>S</sub>M .....

**LOCALITY SKETCH PLAN**

Parish **Condobolin** ..... County **Forbes** ..... City or Town.....  
 Municipality or Shire **Forbes** ..... Control Survey Plan.....

Measurements are in metres Zone 55/2

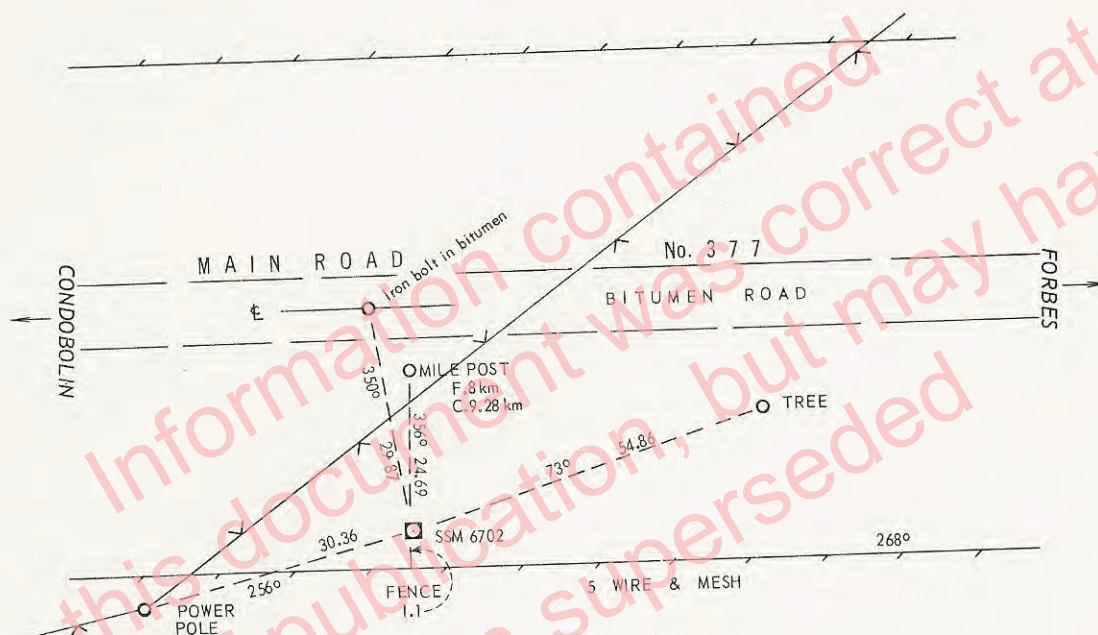

Information contained in this document was correct at time of publication, but may have been superseded

Organisation placing Marks

Department of Main Roads  
 Aerial photo No. 5201.... Run NSW 1502/4  
 Plan registered / /19  
 Mark last inspected / /19

PM .....  
 SSM 6702 .....  
 M<sub>S</sub>M .....

I certify that the Mark or Marks have been placed and numbered as detailed hereon.

*Sam Jones* 20th Oct 74  
 Designation  
 Assistant Surveyor



**SURVEY BEACON PLATFORM  
FOR CONCRETE RESERVOIRS**

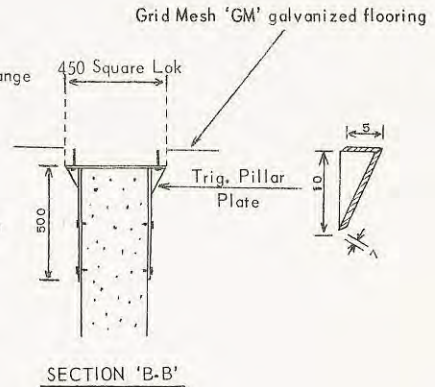
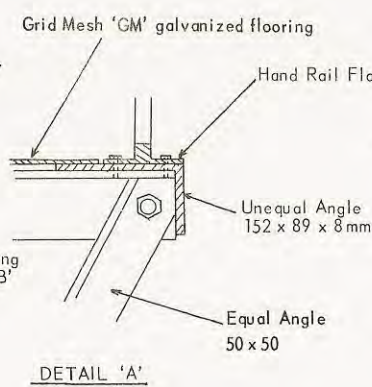
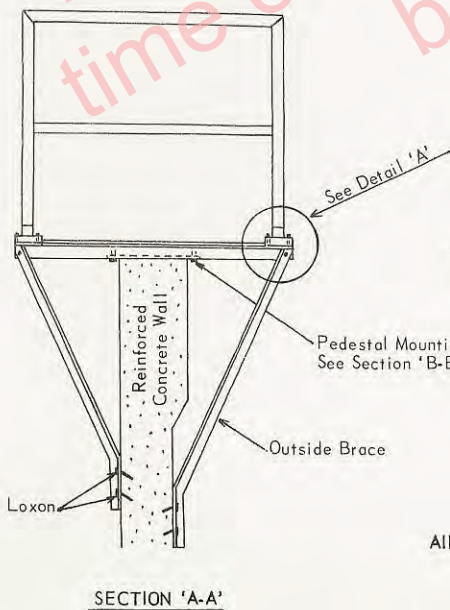
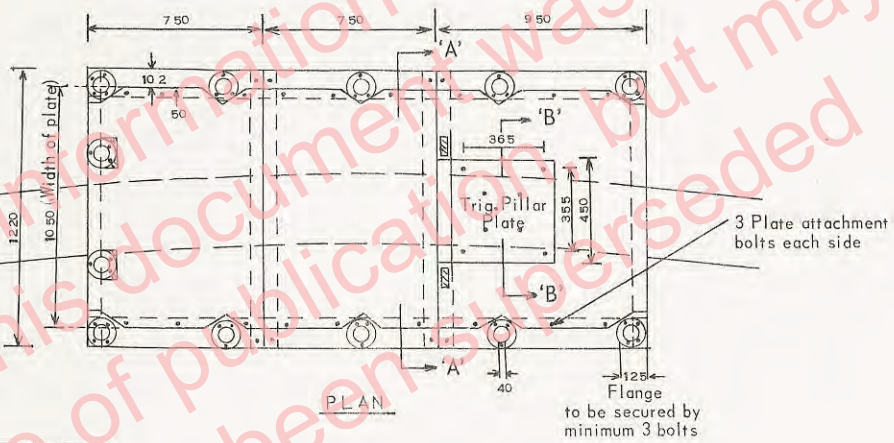
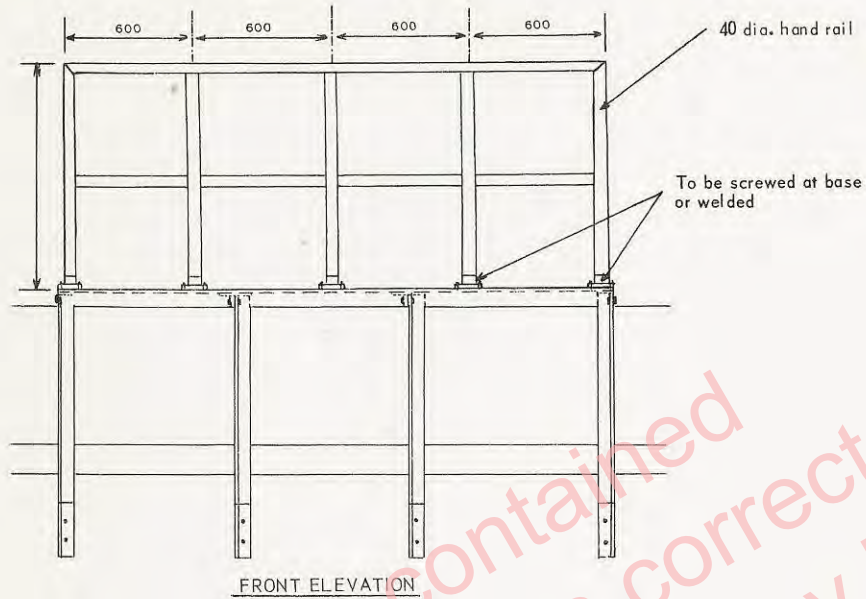

All angle Hand Rail and flooring to be galvanized